

FIXED SIP DELAY LINE

$T_R < 1ns$

(SERIES 2020 & 2021)



FEATURES

- Microstrip Technology
- Fast rise time for high frequency applications
- Delay available from 100ps to 2500ps
- Very narrow device (SIP package)
- Stackable for PC board economy
- Epoxy encapsulated
- Meets or exceeds MIL-D-23859C

PACKAGES

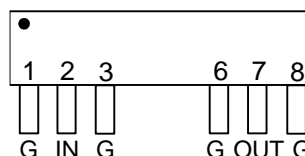

2020-xx
xx = Delay (T_D)

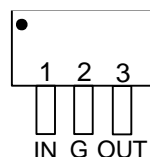

2021-xx
xx = Delay (T_D)

FUNCTIONAL DESCRIPTION

The 2020- and 2021-series devices are fixed, single-input, single-output, passive delay lines. The signal input (IN) is reproduced at the output (OUT), shifted by a time (T_D) given by the device dash number. The characteristic impedance of the lines is nominally 50 ohms. The rise time (T_R) of the lines is less than 1ns, resulting in a 3dB bandwidth in excess of 700MHz.

PIN DESCRIPTIONS

IN Signal Input
OUT Signal Output
G Ground

SERIES SPECIFICATIONS

- **Tolerance:** 2% or 10ps
- **Bandwidth:** >700MHz
- **Ripple in pass-band:** Approx. 0.2dB
- **Dielectric breakdown:** >500 Vdc
- **Operating temperature:** -65°C to +125°C
- **Temperature coefficient:** <100 PPM/°C

DASH NUMBER SPECIFICATIONS

Part Number	Part Number	Delay (ps)	Imped. (Ω)
2021-100	2020-100	100 \pm 10	50
2021-150	2020-150	150 \pm 10	50
2021-200	2020-200	200 \pm 10	50
2021-250	2020-250	250 \pm 10	50
2021-300	2020-300	300 \pm 10	50
2021-350	2020-350	350 \pm 10	50
2021-400	2020-400	400 \pm 10	50
2021-500	2020-500	500 \pm 10	50
2021-600	2020-600	600 \pm 12	50
2021-700	2020-700	700 \pm 14	50
	2020-800	800 \pm 16	50
	2020-900	900 \pm 18	50
	2020-1000	1000 \pm 20	50
	2020-1100	1100 \pm 22	50
	2020-1200	1200 \pm 24	50
	2020-1300	1300 \pm 26	50
	2020-1400	1400 \pm 28	50
	2020-1500	1500 \pm 30	50
	2020-1600	1600 \pm 32	50
	2020-1750	1750 \pm 35	50

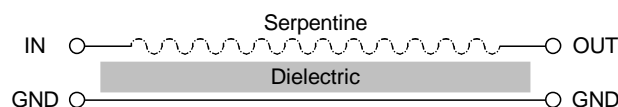

Functional Diagram

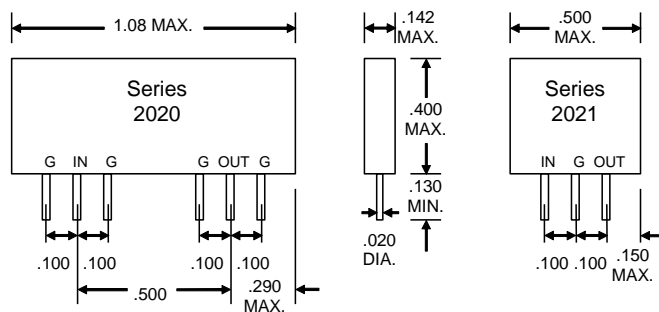

Package Dimensions

PASSIVE DELAY LINE TEST SPECIFICATIONS

TEST CONDITIONS

INPUT:

Ambient Temperature: 25°C ± 3°C
Source Amplitude: 0dBm typical
Source Impedance: 50Ω nominal
Input Frequency: 27.777778MHz

OUTPUT:

Z_{load}: 50Ω nominal

Network analyzer is used in phase measurement mode, normalized with a wire jumper between input and output of DUT test socket. Delay is related to phase lag with proportionality constant of 100ps/deg.

NOTE: The above conditions are for test only and do not in any way restrict the operation of the device.

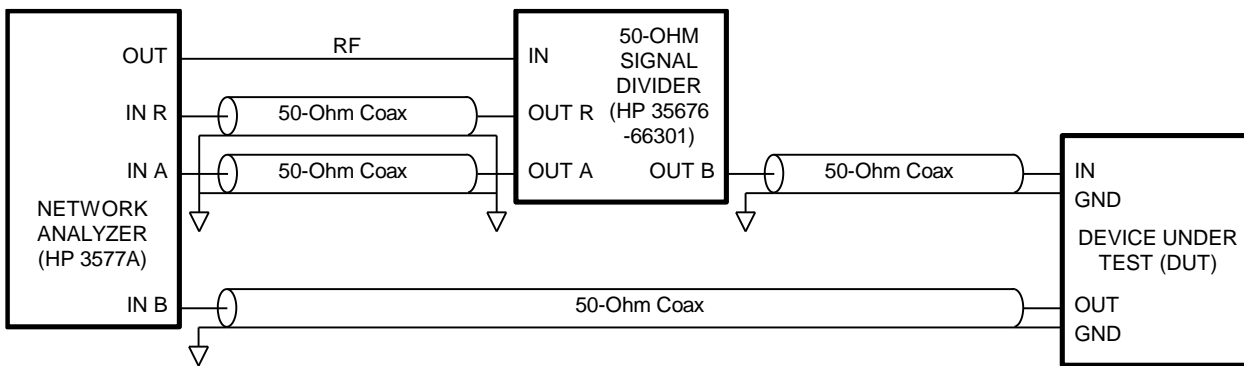

Test Setup